

Lead Vacuum - For Safe Recovery of Lead Dust & Paint

FEATURES

Non-woven, embossed, polyester filter bag provides 50% more filtration area than standard bags. Filter is 99.9% efficient at 3.0 microns.

Equipped with H.E.P.A. (High Efficiency Particulate Air) Filter which is 99.99% efficient at 0.12 microns.

State-of-the-Art polypropylene lid assembly is acoustically designed to minimize noise . . . 74 dba.

Polyethylene tanks are durably constructed, noncorrosive and dent-proof for years of reliable service.

The "sure-grip/quick-release" mechanism makes it easy to connect and remove hoses.

Convenient 50 foot cord.

All models are available in 115 volt and 240 volt models.

Optional electric powerhead available.

Each unit comes standard with a dry tool kit, which includes:

1-1/4" x 8 ft. Crush Proof Hose (3 cm x 1.8 m)

1-1/4" Wand (3 cm) - *not pictured*

12" Crevice Tool (30 cm)

5" Upholstery Tool (13 cm)

11" Combination Floor/Carpet Tool (28 cm)



DRY ONLY LEAD VACUUM OPERATION

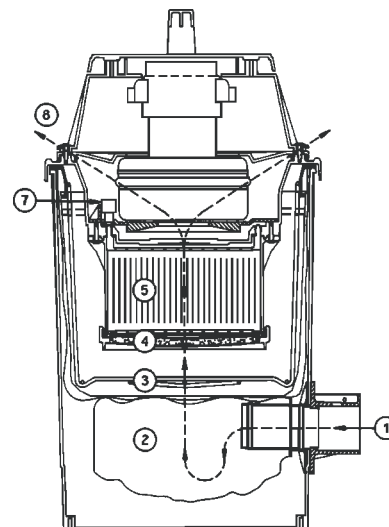

- 1) Intake
- 2) Collect Bag
- 3) Cloth Filter
- 4) Impact Filter
- 5) H.E.P.A. Filter
- 6) Exhaust
- 7) Safety Interlock

SPECIFICATIONS

	C82985-06	C82986-06
VOLTAGE:	115 volt	240 volt
TANK SIZE:	6 gal (22 ltr)	6 gal (22 ltr)
POWER:	1.25 hp	1.25 hp
AIR FLOW:	95 CFM	95 CFM
WATER LIFT:	85Ž (2159 mm)	85Ž (2159 mm)
DRY CAPACITY:	.46 cu ft (.01m ³)	.46 cu ft (.01m ³)
CORD:	16-3, 50Ŧ (15 mm)	16-3, 50Ŧ (15 mm)
CASTERS:	1-5/8Ž (1.13 cm)	1-5/8Ž (1.13 cm)
WEIGHT:	17 lbs (8 kg)	17 lbs (8 kg)



318 Hill Ave.
Nashville, TN 37210
(615) 254-0841
Fax: (615) 726-2514

171 Grayson Road
Rock Hill, SC 29732
(803) 366-5131
Fax: (803) 366-2005